

FIG. C-292TL-F:

**THREADED ENDS, ¼" TO 2": 2000 W.O.G API 607 FIRE-SAFE DESIGNED,
2 ½" TO 4": 1500 W.O.G.**

Features:

- Strengthened construction secures 2000 psi working pressure rating. Reinforced TFE seats increase durability.
- Adjustable packing gland.
- Bottom-loaded blow-out proof stem.
- Basic design complied with ANSI B16.34 & EN 12516-1.
- NPT threaded ends complied with ANSI B 1.20.1..
- Re, Rp & G Threaded ends complied with BS 21/2779, JIS B- 0203/0202, DIN 259/2999, ISO 228-1, ASI 722.1/1722.2 are upon request.
- Graphite gasket & stem packing prevent post-fire external leakage.
- Post-fire metal to metal seal prevents internal leakage after fire.
- Tested according to API 598

Materials List:

NO.	PARTS	C-292TL-F
1	BODY	ASTM A216-WCB
2	END CAP	ASTM A216-WCB
3	SEAT	REINFORCED TFE
4	BALL	ASTM A351- CF8 /304
5	THRUST WASHER	PTFE
6	GASKET	GRAPHITE
7	STEM	ASTM A276-304
8	STEM PACKING	GRAPHITE
9	GLAND	AISI 304
10	HANDLE WASHER	AISI 304
11	HANDLE NUT	AISI 304
12	HANDLE	ZINC PLATED STEEL
13	HANDLE COVER	PVC

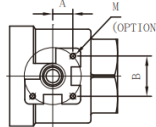
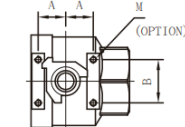
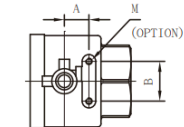
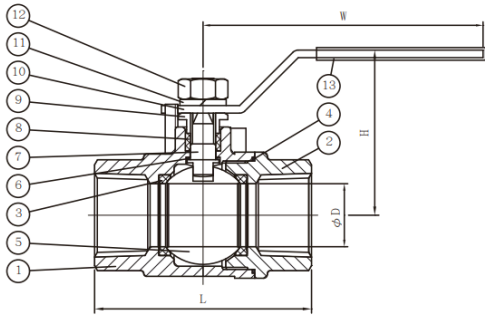
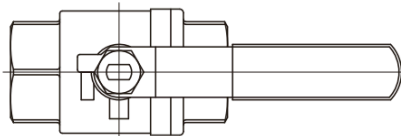

FOR 1 ¼"~2"

FOR 2 ½"~3"

FOR 4"

OPTIONS:

- F: FIRE-SAFE DESIGN.
- L: LOCKING DEVICE.
- M: TAPPED MOUNTING PAD.
- V: VENTED BALL.

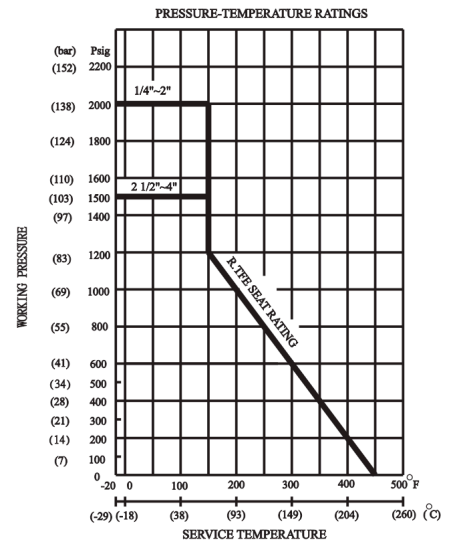

Dimension

SIZE		ØD		L		A		B		H		w		Weight		M (OPTION)
in	mm	in	mm	in	mm	in	mm	in	mm	in	mm	in	mm	lbs	kgs	
¼	8	0.43	11.00	2.24	57.00	0.50	12.70	1.12	28.50	2.13	54.00	3.70	94.00	0.56	0.25	10-24UNC
⅜	10	0.49	12.50	2.24	57.00	0.50	12.70	1.12	28.50	2.13	54.00	3.70	94.00	0.62	0.28	10-24UNC
½	15	0.59	15.00	2.54	64.50	0.50	12.70	1.12	28.50	2.24	57.00	3.70	94.00	0.73	0.33	10-24UNC
¾	20	0.79	20.00	2.87	73.00	0.87	22.10	1.38	35.00	2.46	62.50	4.37	111.00	1.02	0.46	10-24UNC
1	25	1.00	25.40	3.37	85.50	0.93	23.60	1.38	35.00	2.87	73.00	5.37	136.50	1.72	0.78	10-24UNC
1 ¼	32	1.26	32.00	3.94	100.00	0.93	23.60	1.50	38.10	3.09	78.50	5.37	136.50	2.67	1.21	1/4-20UNC
1 ½	40	1.50	38.00	4.41	112.00	0.93	23.60	1.50	38.10	3.48	88.50	6.57	167.00	3.89	1.77	1/4-20UNC
2	50	1.97	50.00	5.12	130.00	0.93	23.60	1.50	38.10	3.84	97.50	6.57	167.00	6.14	2.79	1/4-20UNC
2 ½	65	2.56	65.00	6.38	162.00	1.38	35.00	2.17	55.00	5.06	128.50	9.57	243.00	14.11	6.40	1/4-20UNC
3	80	3.15	80.00	7.09	180.00	1.38	35.00	2.17	55.00	5.49	139.50	9.57	243.00	20.45	9.28	1/4-20UNC
4	100	3.94	100.00	9.09	231.00					6.59	167.50	10.79	274.00	45.41	20.60	M10